

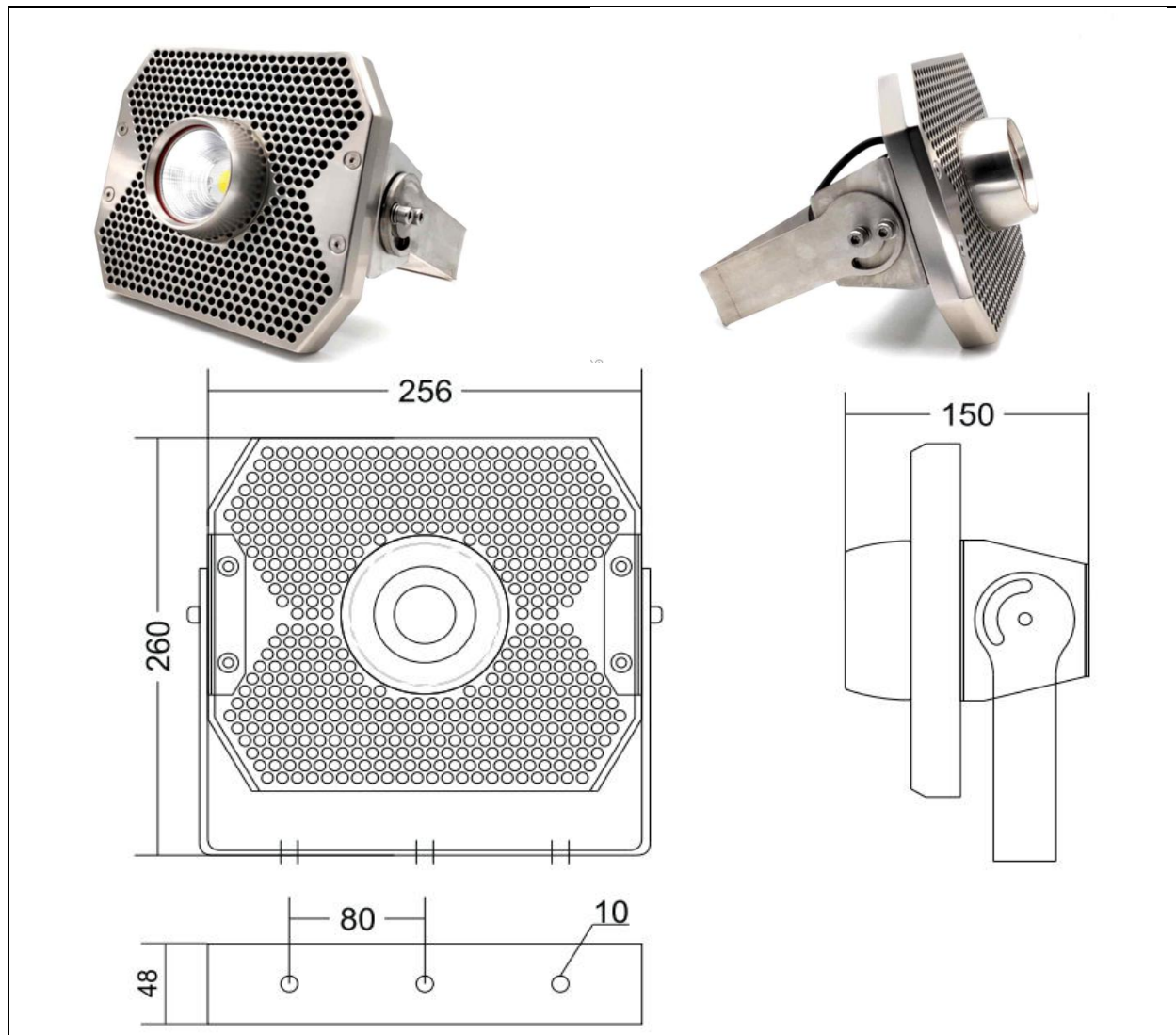

PRODUCT CODE	DESCRIPTION
FL-50	HEAVY DUTY MARINE LED FLOOD LIGHT
TECHNICAL DETAILS	
POWER:	55W
VOLTAGE:	100-240V
PROTECTION:	IP67
LED LIFETIME:	72.000 HOURS
LIGHT ANGLE:	21° / 35° / 64°
COLOR TEMPERATURE:	3000-5000K; CRI>80
LIGHT BEAM:	6.516 LM
FREQUENCY:	50-60Hz
WARRANTY:	5 YEARS
INRUSH CURRENT:	Imax 69,8A; 160µs
WORKING TEMPERATURE:	-35°C + 45°C
DIMENSIONS:	256mm x 260mm x 150mm
APPROVALS:	BUREAU VERITAS Marine Approval
HOUSING MATERIAL:	Marine grade anodized aluminum (sea water resistant)
BRACKET MATERIAL:	Stainless Steel AISI 316L

PICTURES & DRAWINGS:



PRODUCT CODE	DESCRIPTION
FL-100	HEAVY DUTY MARINE LED FLOOD LIGHT
TECHNICAL DETAILS	
POWER:	105W
VOLTAGE:	100-240V
PROTECTION:	IP67
LED LIFETIME:	72.000 HOURS
LIGHT ANGLE:	21° / 35° / 64°
COLOR TEMPERATURE:	3000-5000K; CRI>80
LIGHT BEAM:	13.630 LM
FREQUENCY:	50-60Hz
WARRANTY:	5 YEARS
INRUSH CURRENT:	Imax 65A; 550µs
WORKING TEMPERATURE:	-35°C + 45°C
DIMENSIONS:	220mm x 318mm x 150mm
APPROVALS:	BUREAU VERITAS Marine Approval
HOUSING MATERIAL:	Marine grade anodized aluminum (sea water resistant)
BRACKET MATERIAL:	Stainless Steel AISI 316L

PICTURES & DRAWINGS:

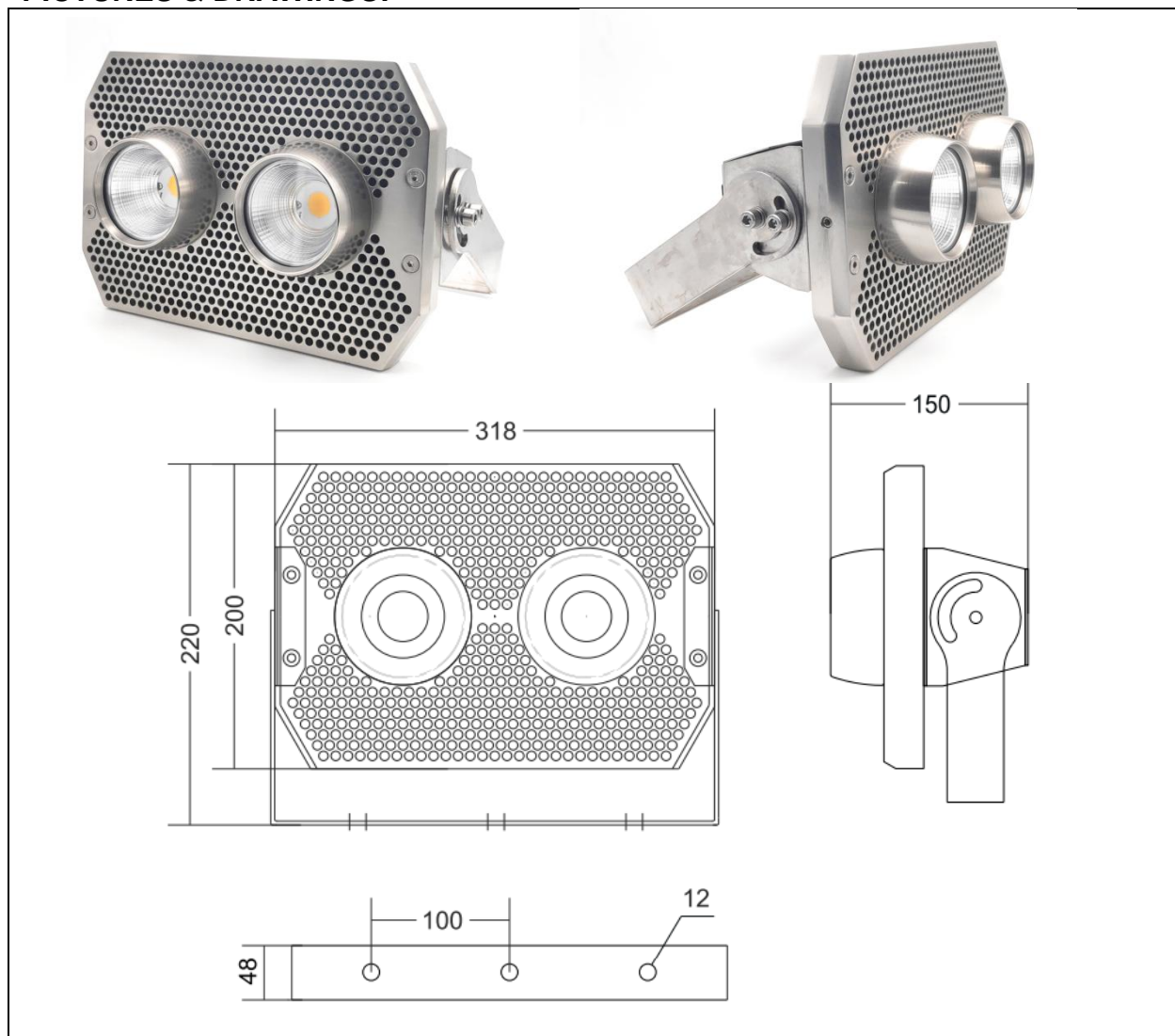



PRODUCT CODE	DESCRIPTION
FL-150	HEAVY DUTY MARINE LED FLOOD LIGHT
TECHNICAL DETAILS	
POWER:	160W
VOLTAGE:	100-240V
PROTECTION:	IP67
LED LIFETIME:	72.000 HOURS
LIGHT ANGLE:	21° / 35° / 64°
COLOR TEMPERATURE:	3000-5000K; CRI>80
LIGHT BEAM:	20.500 LM
FREQUENCY:	50-60Hz
WARRANTY:	5 YEARS
INRUSH CURRENT:	I _{max} 65A; 550µs
WORKING TEMPERATURE:	-35°C + 45°C
DIMENSIONS:	260mm x 380mm x 150mm
APPROVALS:	BUREAU VERITAS Marine Approval
HOUSING MATERIAL:	Marine grade anodized aluminum (sea water resistant)
BRACKET MATERIAL:	Stainless Steel AISI 316L

PICTURES & DRAWINGS:

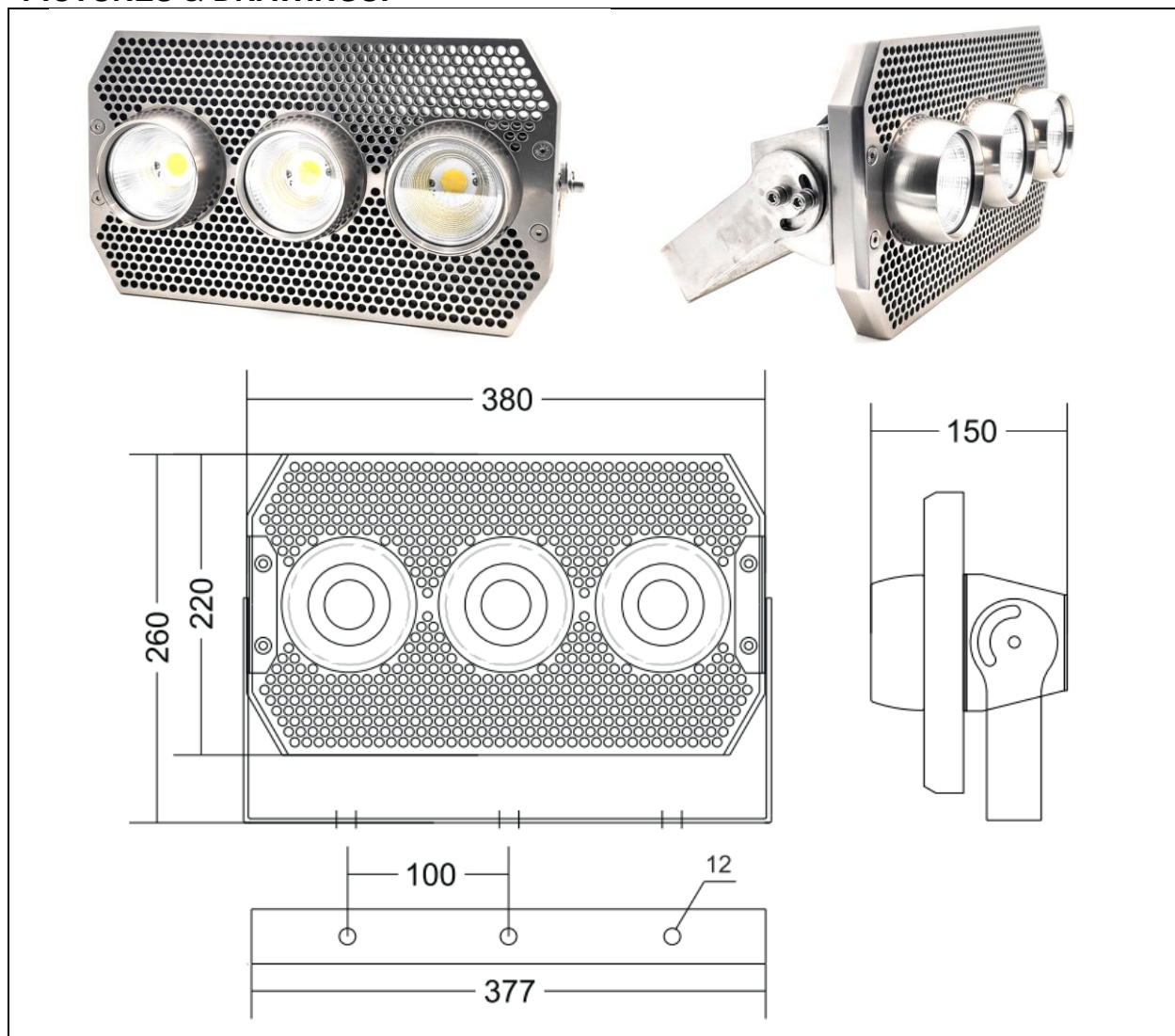



PRODUCT CODE	DESCRIPTION
FL-200	HEAVY DUTY MARINE LED FLOOD LIGHT
TECHNICAL DETAILS	
POWER:	210W
VOLTAGE:	100-240V
PROTECTION:	IP67
LED LIFETIME:	72.000 HOURS
LIGHT ANGLE:	21° / 35° / 64°
COLOR TEMPERATURE:	3000-5000K; CRI>80
LIGHT BEAM:	27.000 LM
FREQUENCY:	50-60Hz
WARRANTY:	5 YEARS
INRUSH CURRENT:	I _{max} 75A; 450µs
WORKING TEMPERATURE:	-35°C + 45°C
DIMENSIONS:	255mm x 473,6mm x 150mm
APPROVALS:	BUREAU VERITAS Marine Approval
HOUSING MATERIAL:	Marine grade anodized aluminum (sea water resistant)
BRACKET MATERIAL:	Stainless Steel AISI 316L

PICTURES & DRAWINGS:

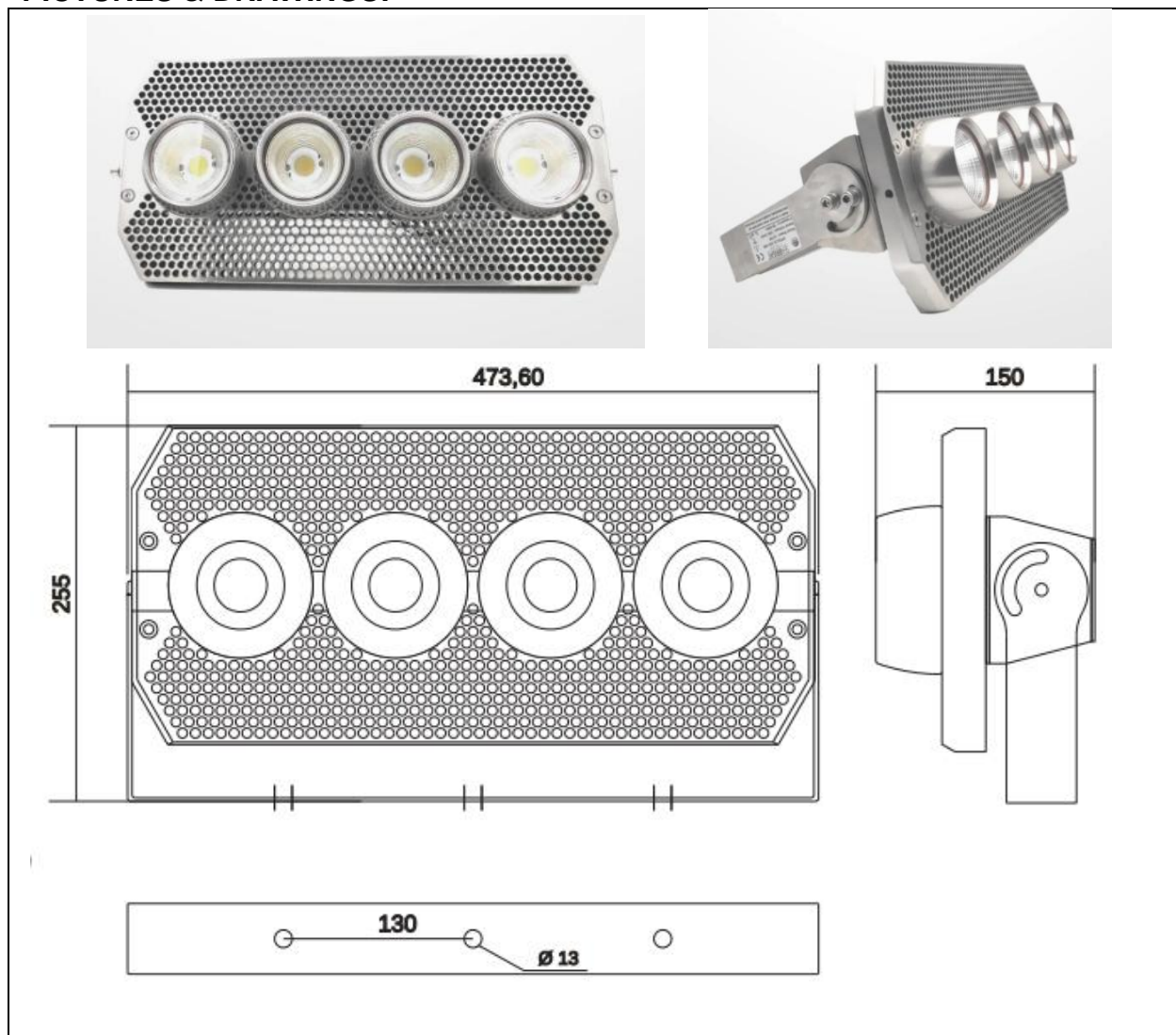

PRODUCT CODE	DESCRIPTION
FL-300	HEAVY DUTY MARINE LED FLOOD LIGHT
TECHNICAL DETAILS	
POWER:	325W - REPLACING 1000W HPS
VOLTAGE:	100-240V
PROTECTION:	IP67
LED LIFETIME:	72.000 HOURS
LIGHT ANGLE:	21° / 35° / 64°
COLOR TEMPERATURE:	3000-5000K; CRI>80
LIGHT BEAM:	41.000 LM
FREQUENCY:	50-60Hz
WARRANTY:	5 YEARS
INRUSH CURRENT:	I _{max} 75A; 450µs
WORKING TEMPERATURE:	-35°C + 45°C
DIMENSIONS:	440mm x 452mm x 215mm
APPROVALS:	BUREAU VERITAS Marine Approval
HOUSING MATERIAL:	Marine grade anodized aluminum (sea water resistant)
BRACKET MATERIAL:	Stainless Steel AISI 316L

PICTURES & DRAWINGS:

